





**MOD. EVOX 5T**

**TECHNICAL FEATURES**

Model	Performance		Capacity in Trays	Standard Tension	Power Consumption	Refrigerant
	(+90°C/+3°C)	(+90°C/-18°C)				
SQX5FT.20	20 kg	12 kg	5 GN 1/1 5 EN 60x40*	230V / 1Ph 50Hz	1,3 kW 7,0 A	R404A 0,700 kg
SQX5FT.20W						
SQX5FT.20R						
SQX5FT.20WR						
SQX5FT.20SG	/	/			0,3 kW 2,0 A	R404A 0,000 kg
SQX5FT.20SGCO <sub>2</sub>						CO <sub>2</sub> 0,000 kg

\* Pastry version is available for EN60x40 shelves only (es.:SQX5FT.20P).

**CONSTRUCTIVE FEATURES**

	Structure in stainless steel AISI 304 18/10 – External: Scotch Brite, interior: mirror finishing		Rounded inner and outer angles cleaning and space under the evaporator for a perfect and easy cleaning
	Certified Italian high performances refrigerating units		Oversized condensers to ensure reliability
	Special fans suitable for low temperature with speed regulation system		Cathaphoresis painted anti-corrosion evaporators

Structure insulation in CFC-free polyurethane DPO-0 ◆ **Door frame completely integrated in the structure itself to grant top hygiene** ◆ Self-closing door equipped with a silicone gasket resistant to low temperatures, magnetic and heated door frame ◆ **Core probe** with strong silicone gum grip **as standard** ◆ Lateral drain hole for condensation and water run out ◆ The technical room of evaporator and condenser can be easily inspected through a compass opening

The appliance is supplied without trays, without trolley, ramp and without mobile oven racks. CO<sub>2</sub> versions are supplied without thermic expansion valve. The manufacturer reserves the right to carry out modifications of the product without notice. For different voltages and/or frequencies quotations on demand.

**A.T.O. S.R.L.** - Via dell'Artigianato, 24 - 31030 Castello di Godego - Treviso – Italy

Reg. Imprese TV - Cod. Fiscale - P.Iva IT 02384740268, REA TV n. 206822 – Shared Capital € 52.000 i.v.

Tel. (+39) (0)423-768270 / Fax (+39) (0)423-469539 – [www.sincold.com](http://www.sincold.com) – [info@sincold.com](mailto:info@sincold.com)

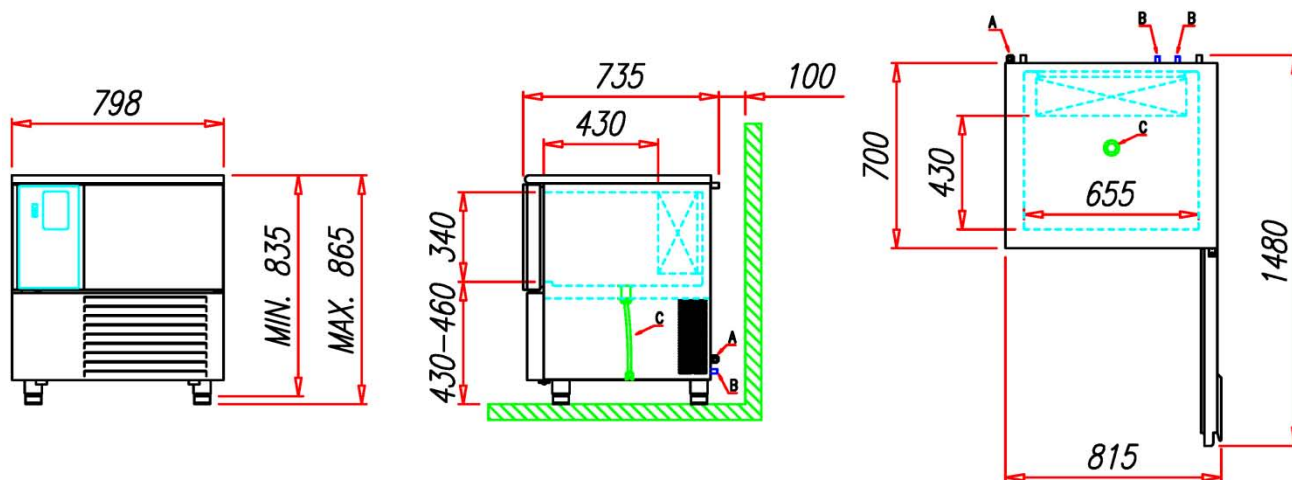

A = Electrical and Water connection (when needed)

B = Refrigeration connection

C = Evaporator water drain pipe

**TECHNICAL DATA**

Modello	Refrigerating Power		Consumption kWh/kg		Net Weight	Insulation Thickness	Room Conditions	Certifications
	*Te = -10°C	*Te = -30°C	(+90°C/+3°C)	(+90°C/-18°C)				
SQX5FT.20	1.750 W	700 W	0,12	0,40	105 kg	70 mm	+32°C 60% UR	
SQX5FT.20W								
SQX5FT.20R								
SQX5FT.20WR								
SQX5FT.20SG								
SQX5FT.20SGCO <sub>2</sub>	/	/	/	/	75 kg			

\* Te = Expansion Temperature – Condensation Temperature = +45°C

**ELECTRONIC CONTROLLER**
**Cycles available:**

- Temperature blast chilling and conservation
- Time blast chilling and conservation
- Temperature deep freezing and conservation
- Time deep freezing and conservation
- Soft and hard cycles for both blast chilling and deep freezing
- Multi timer non-stop cycle
- Pre-cooling

**Optional cycles:**

- Multi core probe non-stop cycle
- Sterilization
- Leavening/proving
- Low temperature slow cooking

**Special functions:**

- Recipe book
- Automatic control on core probe insertion
- raw fish sanitation
- Thawing
- Manual defrost
- Special cycle for ice cream
- Drying
- Evaporator fan speed regulation
- USB

**Optional functions:**

- Core probe heating
- Multipoint core probe
- Multi core probe







 The appliance is supplied without trays, without trolley, ramp and without mobile oven racks. CO<sub>2</sub> versions are supplied without thermic expansion valve. The manufacturer reserves the right to carry out modifications of the product without notice. For different voltages and/or frequencies quotations on demand.

**A.T.O. S.R.L.** - Via dell'Artigianato, 24 - 31030 Castello di Godego - Treviso – Italy

Reg. Imprese TV - Cod. Fiscale - P.Iva IT 02384740268, REA TV n. 206822 – Shared Capital € 52.000 i.v.

Tel. (+39) (0)423-768270 / Fax (+39) (0)423-469539 – www.sincold.com – info@sincold.com

**ACCESSORIES (OPTIONAL)**

	Leavening and Slow cooking	ACC FO1		Led light	ACC 147
	Ramp (1 piece)	ACC 140		Left opening door	ACC 135
	Ozone Sterilizer	ACC 110		Heated Core Probe	ACC 509
	Multipoint core probe	ACC 510			

**DATA SHEET ACCORDING TO prEN 17032**

Model	Product Type	Refrigerating Gas			Program	
		Type	GWP	Charge	Blast Chilling	Deep Freezing
SQX5FT.20	BLAST CHILLER DEEP FREEZER	R404A	3922	0,700 kg	HARD	TIME
SQX5FT.20W						
SQX5FT.20R						
SQX5FT.20WR						
SQX5FT.20SG						
SQX5FT.20SGCO <sub>2</sub>		CO <sub>2</sub>	1	0,000 kg	/	/

Model	Blast Chilling (+65°C / +10°C)			Deep Freezing (+65°C / -18°C)		
	Maximum Capacity	Energy Consumption E	Time t	Maximum Capacity	Energy Consumption E	Time t
SQX5FT.20	20 kg	0,12 kWh/kg	120 min.	12 kg	0,40 kWh/kg	260 min.
SQX5FT.20W						
SQX5FT.20R						
SQX5FT.20WR						
SQX5FT.20SG	/	/	/	/	/	/
SQX5FT.20SGCO <sub>2</sub>	/	/	/	/	/	/

Manufacturer: A.T.O. S.R.L. - Via dell'Artigianato, 24 - 31030 Castello di Godego - Treviso – Italy

**STANDARD PACKAGE**

Package	External Dimensions			m <sup>3</sup>	Gross Weight	
	Width	Depth	Height		Standard	SG Version
1	890 mm	845 mm	1050 mm	0,79	125 kg	95 kg

The appliance is supplied without trays, without trolley, ramp and without mobile oven racks. CO<sub>2</sub> versions are supplied without thermic expansion valve. The manufacturer reserves the right to carry out modifications of the product without notice. For different voltages and/or frequencies quotations on demand.

A.T.O. S.R.L. - Via dell'Artigianato, 24 - 31030 Castello di Godego - Treviso – Italy

Reg. Imprese TV - Cod. Fiscale - P.Iva IT 02384740268, REA TV n. 206822 – Shared Capital € 52.000 i.v.

Tel. (+39) (0)423-768270 / Fax (+39) (0)423-469539 – www.sincold.com – info@sincold.com