

MAR 79 **EcoX**

Modular Ice Machine 540 kg

Item #:
Project:
Quantity:



FEATURES

- Scale ice machine, in split system" version; built-in unit. Storage bin not supplied, to be purchased separately.
- To be connected to condensing unit or central cooling system (low temperature).
- AISI304 Stainless steel evaporator and ice scraper blade. Redesigned evaporator compartment end-walls.
- Foodgrade ABS plastic water sump tray, easy remove for cleaning and sanitising.
- Electromechanical control panel. Electrical protections, rotation speed & reverse phase controls.
- Low- water sensor protection. Storage bin thermostatic ice level sensor. Drive motor / gear reducer with V-Belt drive.
- Stainless steel panels in scotch-brite finish, with rounded corners, easy to remove for maintenance.
- Supplied w/ electronic expansion valve, pressure regulating valve (KVR), liquid line safety valve 60bar, suction line safety valve 30bar.



MAR 79
Scale ice
Residual water content 2%
Thickness 1 or 2 mm

CONDENSING SYSTEM

SPLIT

REFRIGERANT GAS

R744

VOLTAGE V/Hz/ph

400/50/3N

RECOMMENDED BINS

Head	Bins		kg
	Bin Model	Weight	
MAR 79	●	UBH1100	553
	●	UBH1600	812
	●	UBH2250	1068
	●	SIS300	137 + 73
	●	SIS700	318 + 73
	●	SIS1350	613 + 73 + 73

LEGEND:

- ✓ : Perfect combination between ice maker and bin
- : Ice chute cut-out performed upon installation
- CBTxxxxxxxx : need additional bin top

CERTIFICATIONS



OPERATING REQUIREMENTS

	Minimum	Maximum
Air temperature	10	43
Water temperature	5	38
Water pressure	1 bar (14 psi)	5 bar (70 psi)
Electrical voltage	-10	+10

IMPORTANT NOTICE:
Models and specifications are subject to change without notice.
This spec sheet is meant for commercial purpose only.
For technical documentation please refer to our service manuals.

Download our free **App Scotsman Ice**
Apple store
Google play
Windows store



www.scotsman-ice.it
www.scotsman-ice.com

Modular Ice Machine 540 kg

MAR 79 EcoX

Modular Ice Machine 540 kg

Item #:
Project:
Quantity:

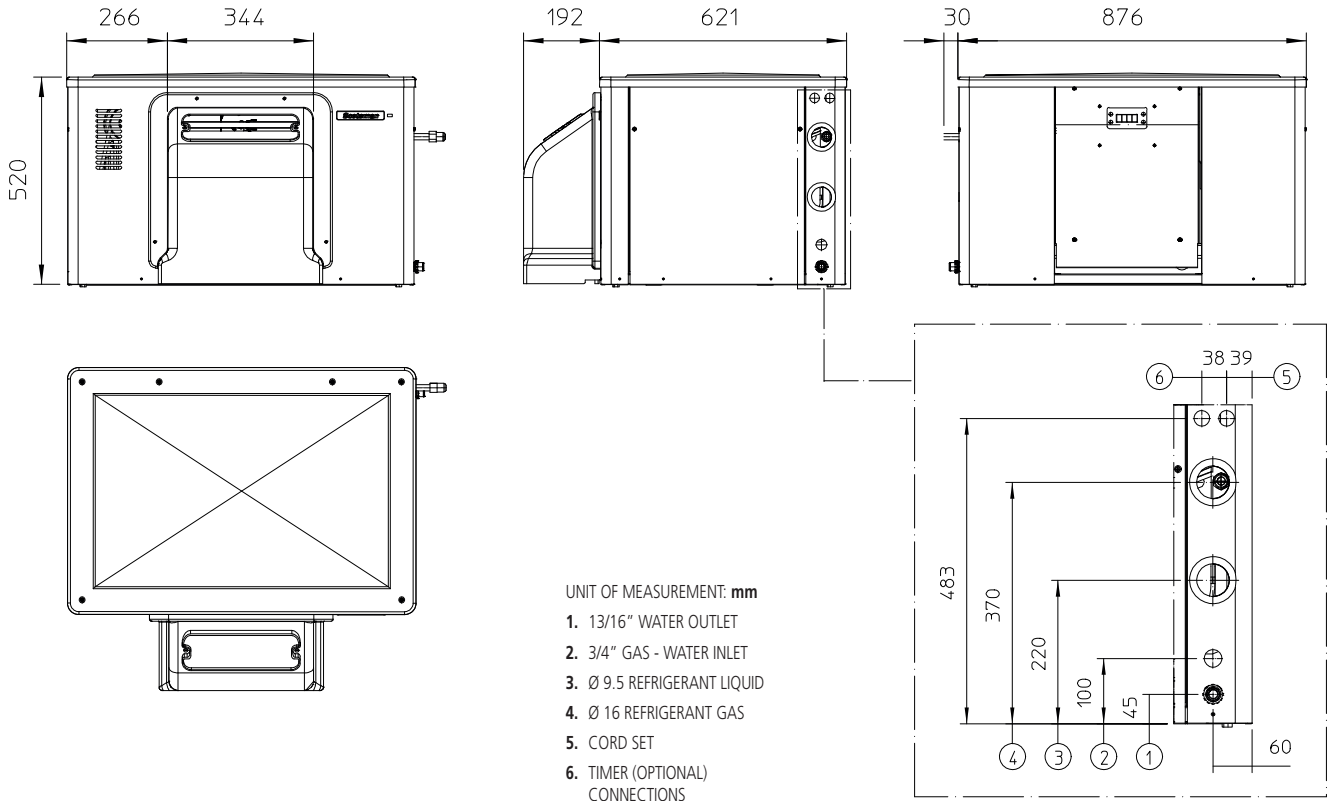

Modular Ice Machine 540 kg

UNIT DATA				SHIPPING DATA											
Size (W x D x H)		906 x 813 x 520 mm		Carton (W x D x H)		980 x 740 x 680 mm									
Net weight		95 kg		Weight		112 kg									
Version	Voltage	24 h ice production kg °C Amb. / °C Water						Energy consumption (*)		Water usage (*)	Instant power	Compressor	Circuit wires	Max. fuse size	
		10°C/10°C		21°C/10°C		32°C/21°C		kWh/100 kg	kWh/24h	l/h	W	W	No. x Ømm²	A	
MAR 79 SPLIT	400/50/3N	540	486	500	486	380	342	1.5	4.8	15.0	200	2800	5 x 2.0	10	
Compressor:		(Te -24.0°C; Tc +10.0°C)													

(*) Data refer to 32°C Amb. / 21°C Water temperature conditions