

MAR 306

Modular Ice Machine 2450 kg

Item #:
Project:
Quantity:



FEATURES

- Scale ice machine, in "compact system" version; built-in unit. Storage bin not supplied, to be purchased separately.
- AISI304 Stainless steel evaporator and ice scraper blade. Redesigned evaporator compartment end-walls.
- Electromechanical control panel.
- Electrical protections, rotation speed & reverse phase controls.
- Low- water sensor protection. Semi-hermetic compressor. Storage bin thermostatic ice level sensor.
- Drive motor / gear reducer with V-Belt drive.
- Stainless steel panels in scotch-brite finish, with rounded corners, easy to remove for maintenance.
- ON/OFF manual switch, with weekly programmable timer.

CONDENSING SYSTEM

Remote condenser
Water cooled

REFRIGERANT GAS

R404A
R452A

VOLTAGE

V/Hz/ph
230/60/3
380/60/3N
400/50/3N
400/60/3

RECOMMENDED BINS

Head	Bins		kg
MAR 306	●	UBH1600	812
	●	UBH2250	1068
	●	SIS1350	613 + 73 + 73



MAR 306
Scale ice
Residual water content 2%
Thickness 1 or 2 mm

LEGEND:

- ✓ : Perfect combination between ice maker and bin
- : Ice chute cut-out performed upon installation
- CBTxxxxxxxx : need additional bin top

CERTIFICATIONS



OPERATING REQUIREMENTS

	Minimum	Maximum
Air temperature	10	43
Water temperature	5	38
Water pressure	1 bar (14 psi)	5 bar (70 psi)
Electrical voltage	-10	+10

IMPORTANT NOTICE:
Models and specifications are subject to change without notice.
This spec sheet is meant for commercial purpose only.
For technical documentation please refer to our service manuals.

Download our free **App Scotsman Ice**
Apple store
Google play
Windows store



www.scotsman-ice.it
www.scotsman-ice.com

Modular Ice Machine 2450 kg

MAR 306

Modular Ice Machine 2450 kg

Item #:
Project:
Quantity:

Modular Ice Machine 2450 kg

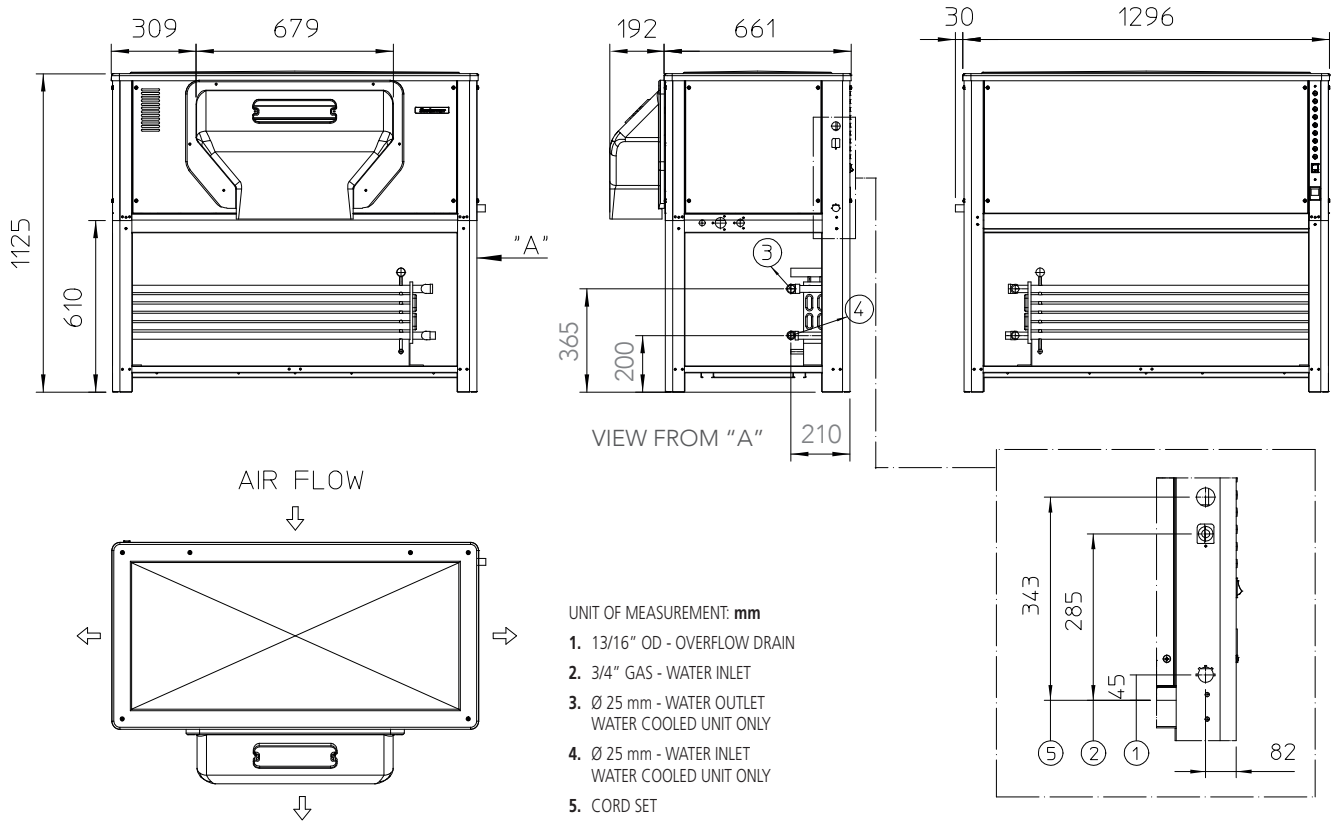

UNIT DATA		SHIPPING DATA		All data refer to R404A refrigerant models
Size (W x D x H)	1326 x 853 x 1125 mm	Carton (W x D x H)	1410 x 790 x 1250 mm	
Net weight	393 kg	Weight	416 kg	

Version	Voltage	24 h ice production kg °C Amb. / °C Water						Energy consumption (*)		Water usage (*)	Instant power	Compressor	Circuit wires	Max. fuse size
		10°C/10°C		21°C/10°C		32°C/21°C		kWh/100 kg	kWh/24h	l/h	W	W	No. x Ømm²	A
MAR 306 ASR	400/50/3N	2350	2050	0	1980	0	1700	11.6	200.0	68.8	8750	13000	5 x 4.0	32
MAR 306 WS	400/50/3N	2450	2200	0	0	0	0	11.6	200.0	416.7	10000	13000	5 x 4.0	32
MAR 306 ASR	230/60/3	0	0	0	0	0	0	13.0	215.0	68.8	9100	13000	4 x 4.0	100
MAR 306 ASR	380/60/3N	0	0	0	0	0	0	11.6	200.0	68.8	8150	13000	5 x 4.0	32
MAR 306 WS	400/60/3	0	0	0	0	0	0	11.6	200.0	416.7	10000	13000	4 x 4.0	32

Compressor: (Te -25.0°C; Tc +45.0°C)

(*) Data refer to 32°C Amb. / 21°C Water temperature conditions